



# 2014 CATALOG

UNC PRO - EUROPEAN CUSTOMIZABLE INFLATABLE FURNITURE LEADER FOR EVENTS

---

2500 SOLD PRODUCTS IN 2013

HIGH QUALITY

MADE IN FRANCE

FROM 1 PIECE

# 1. PRESENTATION

WHY UNC PRO AND INFLATABLE FURNITURE ?

# PRESENTATION

- 1 Custom-made by French manufacturers
- 2 Unique European customization
- 3 A full range of designed inflatable furniture
- 4 A complete range of 100% customizable furniture
- 5 Available for rent or purchase
- 6 Well reviewed by prestigious brands worldwide

MORE THAN 800 CLIENTS SINCE 2012



# PRESENTATION

1

Launched in 2011, UNC Pro distinguishes itself as the **forerunner** and **leader** of customizable inflatable furniture for events marketing and brand development.

2

Thanks to a **unique production line**, we individually manufacture our clients' orders, whether 1 piece or 100.

3

1 embroidery, 3 embroideries, 15cm, 35cm, 45cm, red, black, white... **whatever you need**, we are here for you.



# 2. THE LINE

INNOVATIVE AND FRENCH MATERIALS

1

UNC Pro's range of inflatable furniture includes the sofa (seats 2), the chair, the ottoman, the rocking-chair, the deckchair, the coffee table and the wellness ball.

2

Each of these models is **available with customization** (embroidery or printing) and in different colors : white, black, red, pink, blue.

3

Covers can be interchanged with one another according to your needs and events.

SOFA

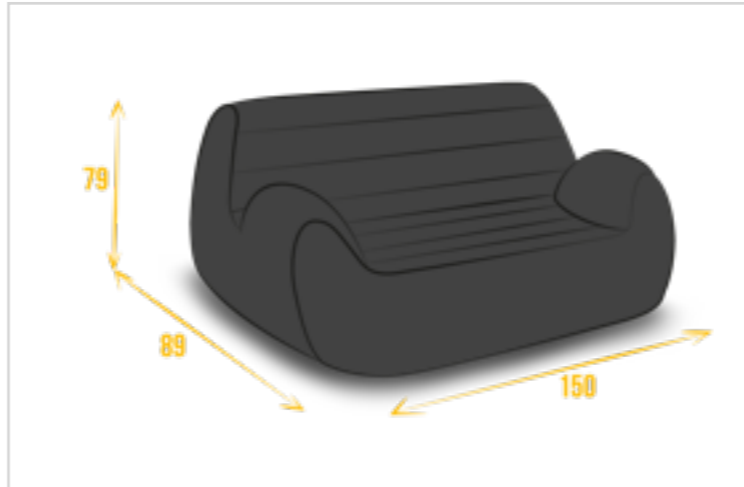

CHAIR

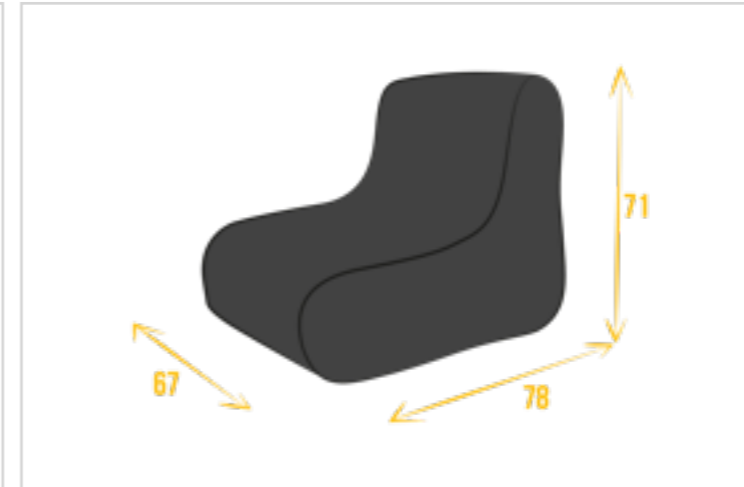

OTTOMAN

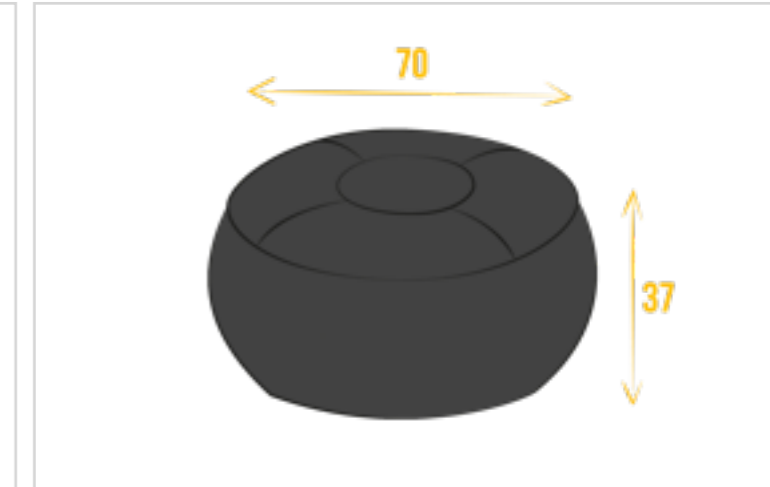

ROCKING-CHAIR

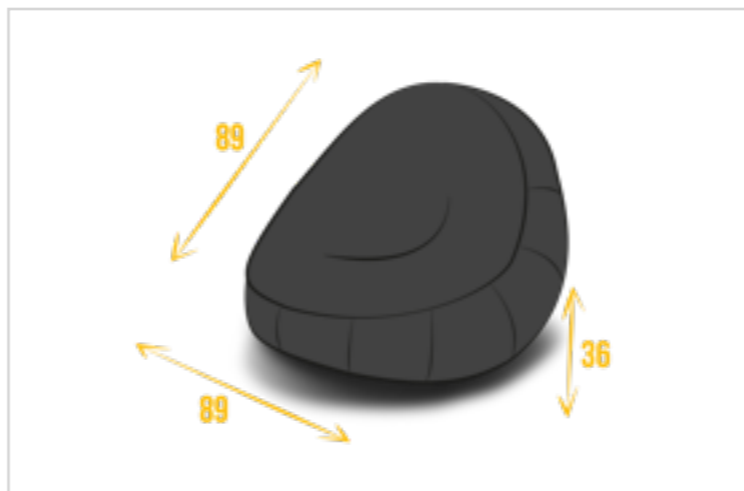

COFFEE TABLE

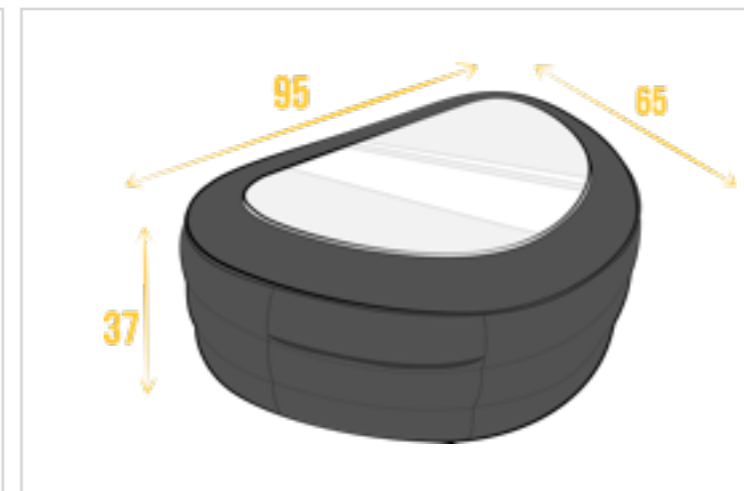

WELLNESS BALL

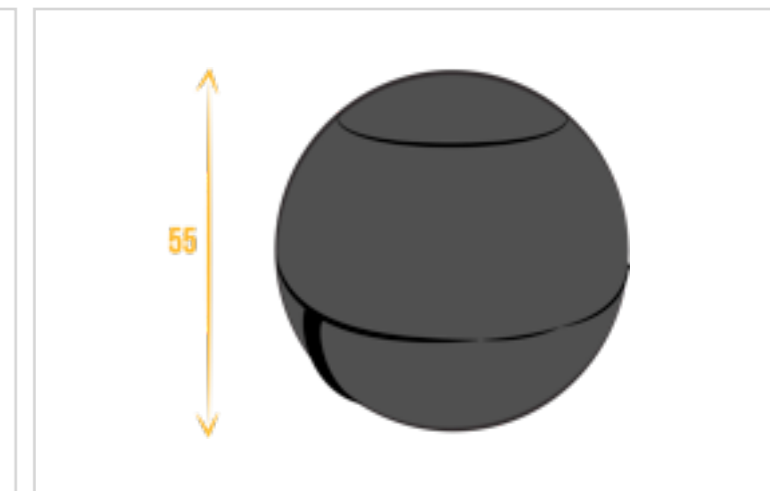

DECKCHAIR

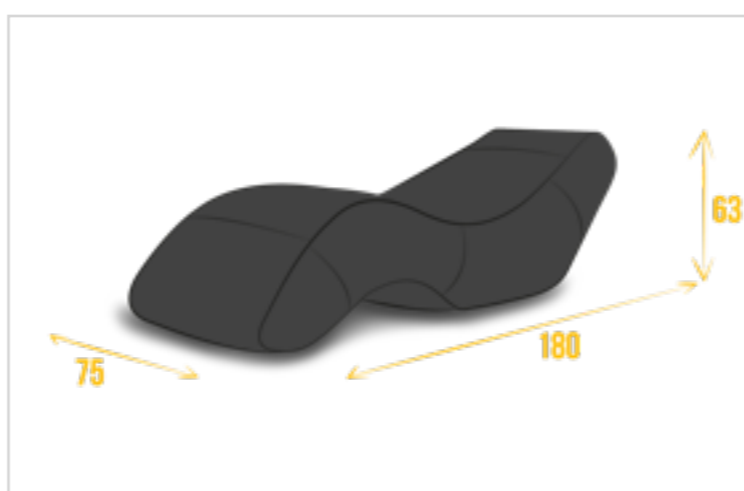

REPAIR KIT



PUMP

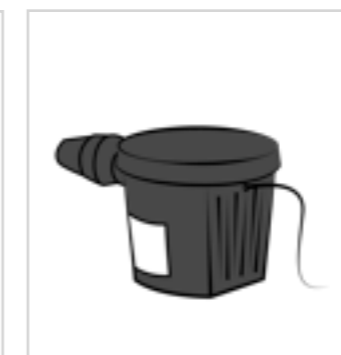

BAG



# 3. CUSTOMIZATION

EMBROIDERY. ULTRA-CUSTOMIZATION. PRINTING.

# CUSTOMIZATION

## EMBROIDERY

1

**High-end customization** for a clean and classy look, embroidery will add value to your brand's image regardless of your market

2

**UNC Pro breakdown** : 1, 2, 3, 4 embroideries per product, 10, 20, 30, 50cm large - we can work with your needs. Available for as few as one unit.

3

**Leadtime** : 2 weeks. Contact-us today to get your 3D layouts with your company's or a client's brand displayed.





# CUSTOMIZATION

## PRINTING

1

**No creative limits.** If you are looking for a product that gives you branding from every angle, then our screen-printing 100% customization option is for you.

2

Launched in 2012 on the European events market, this is a **UNC Pro Innovation** that can be used on as few as 1 unit.

3

**Leadtime** : 2 weeks. Contact-us now for getting your 3D layouts with your own brand (or client's brand).



# CUSTOMIZATION

ULTRA-CUSTOMIZATION

NEW  
**CHOOSE**

1. The color of each of your textile cuts
2. The color of the sewing thread
3. The color of your zipper
3. The place of your embroideries
4. The size of your embroideries
5. The quantity of embroideries per product

AVAILABLE FROM 1 UNIT ORDERED



# 4. RENTAL

OPT FOR SIMPLICITY

# RENTAL

1

Every model of UNC Pro inflatable furniture is available for rent or purchase. Our rental inventory includes **more than 150 units** with the textile color black.

2

Easy to carry, set-up, and store, you can easily manage your own event installations and optimize your budget.

**Set-up time per product** : 3 minutes



# 4. REFERENCES

CLIENTS AND AWARDS

# AWARDS

1

First place at the National Competition for Business Creation organized by Creatests, 2011

2

Jury Special Prize at the CCIP E-Commerce Palms, 2011

3

Best 2012 Young Entrepreneur Prize organized by Le Petit Poucet, 2012

4

First Place for innovation and Entrepreneurship at ESCP Europe, 2011

5

Winner of the Moovjee Prize, 2011

6

First place at RMC INFO Bougeons-Nous, 2011



# REFERENCES

---

Tag Heuer, Mumm Champagne (Grand Prix F1 de Monaco), Quiksilver, Google, Monster energy, Mercedes, SFR, FNAC Festival, 24h du Mans, Société Générale, UBS, Coca-Cola, Carlsberg, Pastis Rosé, EA Sports, Mc Do Kids Sport, Oreo, Winter X Games, Pirelli, Jeep, NRJ, Hugo Boss, INTEL USA, Val D'Isère, La Plagne, Oakley, Rayban, L'Equipe, Dakar, Posca, Fortuneo, M6 Web, Corona Extra, Snickers, Scott, Lafuma, Dakine, Stabilo, Opel, FF Athlétisme, FF Volley Ball, Melty, Orangina, Schweppes, Club Med, Mini Cooper, Roxy, Renault Sport, Canal+ Events, Alice Evénements, Conseil Général de Savoie, Sosh Freestyle Cup, Genève plage, Evian, Badoit, Kia Motors, Pacific, 51 Piscine, Champagne Henriot, Superdry, Jaguar, Contour, Kiloutou, Défi Wind 2013, Lagardère Métropole, Auchan, Hoka One, Apérol, Apec, Adrenaline, FISE, Tignes, Wolter Kluwers, Kurt Salmon, Peugeot, XBOX, IFTM, Cap Com, etc.



# CONTACTS

---

Your contact :

Erich Grossar

+43 6228 2216

[info@grossar.net](mailto:info@grossar.net)

[www.grossar.net](http://www.grossar.net)

